

TriboVacDry 100/450-HVP

Danvac, Inc.

Providing Uncommon Vacuum Pump Solutions to Industry...

TO PLACE AN ORDER CALL 1-866-332-6822

www.danvac.com

Standard Series TriboVacDry...

The 4th Gen TriboVacDry oil-free, high vacuum pumps offer more "real world" solutions to "real world" application needs.

Standard series TriboVacDry pumps contain the molecular drag module backed by diaphragm modules in a single housing.

This completely self-contained unit takes full advantage of

multi-stage pump performance to deliver optimal gas flow efficiency for a myriad of vacuum applications.

TriboVacDry technology means you can use the ultimate pressure performance and chamber volume of your system to determine the most efficient pump model to meet application requirements.



The 4th Gen TriboVacDry Vacuum Pump

Standard Features...

- ◆ Single switch operation
- ◆ Digital hour meter
- ◆ Restart under vacuum
- ◆ Auto-purging
- ◆ Staggered valve sequencing
- ◆ Low maintenance
- ◆ High vacuum isolation
- ◆ Vibration isolation
- ◆ Sophisticated noise suppression
- ◆ Focused forced-air cooling
 - ◆ Can extend diaphragm life in excess of 10,000 hours
- ◆ Rugged enclosure
 - ◆ All steel construction
 - ◆ Durable finish
 - ◆ Impact resistant
 - ◆ Designed to protect internal components

TD-100/450-HVP Specifications...

Rated to pump chamber volumes of	150 liters (5.29 ft ³) or less
Pumping range - torr (mbar)	Atmosphere to 7x10 ⁻⁹ (9.33x10 ⁻⁹)
High vacuum pumping speed - cfm (l/s)	450 (212.40)
Turbo/Drag rotational speed - rpm	60,000
Bearings - Main/Secondary	Magnetically levitated/Oil lubricated
Inlet connection	NW100 or 6.0" CFF
Exhaust connection	1/4" NPT Muffler (Optional barbed, hose fitting supplied)
Roughing/Backing pump	Diaphragm
Number of stages	5
Voltage	120 VAC, 60 Hz / 220 VAC, 50 Hz
Amps - Start/Run @ 120VAC	9.7 / 4.7
Dimensions - inches (cm) LxWxH	21 (53.34) x 15.625 (39.69) x 11.5(29.21)
Weight - lbs. (kg)	83 (37.65)

TriboVacDry 100/450-HVP

TD-100/450-HVP Diagram...

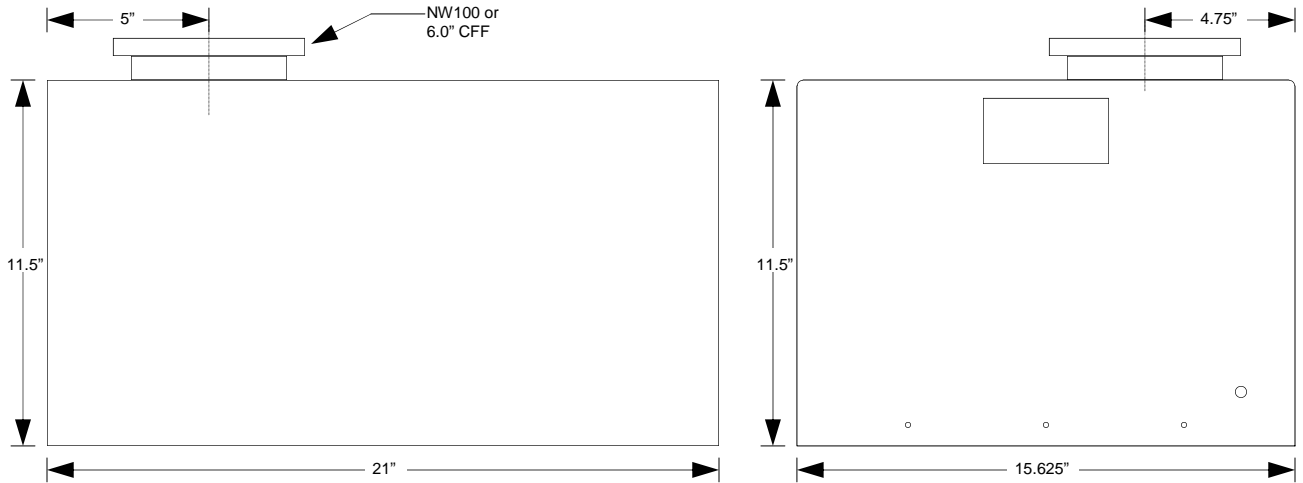

Pumpdown Performance...

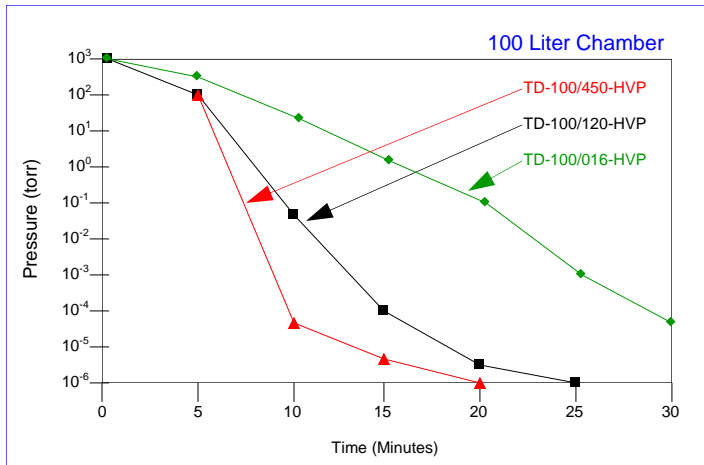

Pumping Speed Curve...

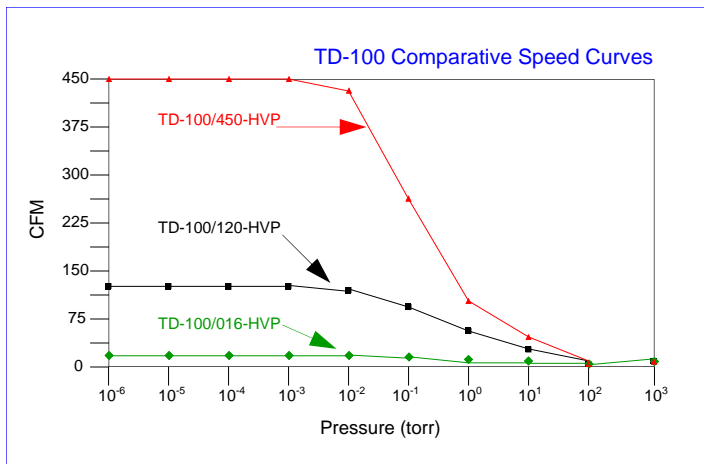

For more information contact:

DANVAC
Uncommon Solutions

DanVac, Inc.
Toll-Free: 1-866-3DANVAC
TEL: 630-678-0700
FAX: 630-678-0701
Email: sales@danvac.com
www.danvac.com